

Erica Titkemeyer  
Basic Training: Sound and Image  
Fall 2011  
Ann Harris

## Not So Pixel Perfect: A Mix Tape of Images

### **Introduction**

The PXL-2000 (also known as Pixelvision) was an attempt in the late 1980's to involve children in the home movie making process without having to lend them their parent's expensive Betamax camcorder. It appeared on the market in 1987 by Fisher-Price, specifically targeted at youth as a lightweight, cheap, user-friendly, and low quality image recording system. Most importantly, the image was not captured on VHS, Beta, or 8 MM, all of which were consumer grade formats of the time. Instead, the system utilized audiocassettes<sup>1</sup>.

Spending a short one to two years on the shelves of toy stores, the PXL-2000 is said to have sold for \$100 to \$250 (depending on whether it was purchased with or without the accompanying monitor), a staggering amount to pay for a child's toy, yet a fifth cheaper than color camcorders for adults at the time<sup>2</sup>. The drawbacks were clear, as the image was black and white, and muddled with consistent video trails and low resolution. Also, with the audiocassette moving at such high speeds over the tape head, only about 10 minutes of recording could fit on a standard 90-minute cassette.

While the PXL-2000 may have been a commercial failure, it was one of the first video cameras to be marketed towards children, while also making an impact on the

---

<sup>1</sup> Thomas Heidt, Camcorder, U.S. Patent 4,875,107, filed December 4, 1986, and issued October 17, 1989, 1.

<sup>2</sup> "A Camcorder the Kids Can Call Their Own," *Consumer Reports* V. 53 (July 1988) P. 423. 53: 423.

aesthetics of experimental and amateur video making. Its influence may only reach a small audience today, and its obsolete technology keeps it from any opportunity for a revival, but it is still an important object to examine for its unconventional technology and cult status.

Following is an exploration of the technological functions of the PXL-2000 and its playback processes, as well as competing formats of the time, user-groups, and preservation issues inherent in the creation and exhibition of the images.

### **The Camera** (see fig.1)

Simply detailed, the body of the Pixelvision is made of plastic, containing an aspheric lens, viewfinder (104), CCD (charge coupled device), cassette compartment (105), control buttons (109-113), handle (102), microphone (115), fixed heads (107), drive shafts (108), and internal electrical circuits for power.

The camera could either receive its power from six AA batteries, or from an AC adapter supplied with purchase<sup>3</sup>. Its light weight (1.1 pounds) made it much more manageable compared to something like a Sony BMC-500, released two years prior, which weighed around 5.5 pounds. The Pixelvision was also frequently commended for its easy trigger record button located on the handle. Compared to most of the early Betacam and VHS camcorders, it was a foolproof camera, allowing for a child as young as eight to operate without difficulties.

---

<sup>3</sup> Andy Hain. "Fisher-Price PXL-2000." Total Rewind.  
[http://www.totalrewind.org/cameras/C\\_PXL2.htm](http://www.totalrewind.org/cameras/C_PXL2.htm).

## Recording Method

The recording process worked similarly to camcorders using other formats at that time, only the difference is seen in the bandwidth, speed at which the tape was moving, and a slightly different encoding process.

Essentially, light travels through the F 5.6, infinite focused lens (meaning everything is focused from one inch of the lens to infinity), and passes through an infrared filter to inhibit any off colors from arriving on the final image. There is also a filter (most likely a neutral density filter) affixed to the lens, which can slide over the aperture for use in outdoor and harsh lighting situations. Next, the light contacts the CCD, which has a 90 X 120 resolution (according to the patent, but other sources describe the final product as having a resolution of 60 X 90). If the CCD did in fact create a 60 X 90 image, the final visual information contained 2,000 pixels, compared to the normal 150,000 in a typical television system<sup>4</sup>. Because of this difference, a black mask was imbedded into the playback, making the image appear in a small box when displayed on a television monitor. This mask kept the image from stretching, which would have created an incoherent jumble of giant pixels. Playback methods will be discussed in further detail later.

Since recording video requires a wider bandwidth than recording audio, the tape must move at a faster rate (roughly 8 times faster) than what is typically considered standard. The result is a bandwidth of 100kHz, which is still diminutive compared to the

---

<sup>4</sup> Andrea McCarty, "Toying with Obsolescence" (MS thesis, Massachusetts Institute of Technology, 2005), 12.

2-4 MHz of a color TV signal<sup>5</sup>. Also, the information acquired by the CCD must be modulated in varying capacities relating to its frequency and voltage. In order for the image to correctly be encoded onto the magnetic tape, it must first be amplified by a preamplifier after leaving the CCD, creating a higher voltage, which is then inputted into the videocassette recorder (VCR) circuit. The VCR circuit converts the CCD information into an FM signal, which is then passed through a record FM limiter, which limits peak values to avoid oversaturation of the tape. The final signal can then be stored on a magnetic tape<sup>6</sup>.

### **The Tape**

With the Walkman having been available since the start of the 1980's, the audiocassette was a recognized analog format. Used by adolescents to listen to music, it became notorious as a format to assemble and share sentimental playlists, a quintessential courting ritual for children of the 80's and 90's. Now Fisher-Price had supplied users with the technological opportunity to make a video love poem of sorts, only problems quickly became apparent, as the image quality was poor, and infamously spooky looking.

An audiocassette (also known as a compact cassette) uses technology first seen with the invention of the Magnetophon, a recorder invented under Nazi Germany, which used a flexible cellulose diacetate base and oxide as the magnetic material for recording audio. This technology was much more useful than the previous wire recorders, which

---

<sup>5</sup> Thomas Heidt, Camcorder, U.S. Patent 4,875,107, filed December 4, 1986, and issued October 17, 1989, 4.

<sup>6</sup> Thomas Heidt, Camcorder, U.S. Patent 4,875,107, filed December 4, 1986, and issued October 17, 1989, 3, 7.

proved to be dangerous when running at high speeds<sup>7</sup>. The audiocassette was yet another improvement, in that it contained the reels within its own carrier, as opposed to its open-reel predecessors.

With the PXL-2000, video is encoded on the left track of the audiocassette, while the audio is recorded onto the right. The limits of the tapes capabilities are easily reached in this process, as a normal 90-minute tape can only hold 10-11 minutes worth of video information, and even still, the image quality is very poor. Lastly, the manual suggests the user purchase the PXL2000 Camcorder high bias tapes, recommending they stray away from ‘poor quality tape’<sup>8</sup>.

**Playback** (see fig. 2)

“The camera allowed an unprecedented degree of privacy for its users due to its incompatibility with other consumer media formats. A video diary shot in Pixelvision must be played back through the camera, and is therefore less likely to cross over into the conventional family media space”<sup>9</sup> - Andrea McCarty

It would be impossible for an individual to hand their secret crush a carefully crafted Pixelvision love tape, expecting that person to have the means for viewing it without their own Pixelvision. Alternatively, it would be a great avenue for confessional filmmaking, as any stranger having the foresight to check for hidden images within a

---

<sup>7</sup> Leo Enticknap, *Moving Image Technology: from zoetrope to digital* (London: Wallflower, 2005), 124.

<sup>8</sup> *PXL 2000 User Manual* (East Aurora: Fisher Price, 1987), 15.

<sup>9</sup> Andrea McCarty, “Toying with Obsolescence” (MS thesis, Massachusetts Institute of Technology, 2005), 49.

found audiocassette is highly unlikely. Unfortunately, this also means there is a necessity for migration when it come to the preservation of these artifacts, which will be discussed later.

There are two separate options for Pixelvision playback, both of which need the camera to act as a tape deck. One option is to utilize the Pixelvision monitor supplied by Fisher-Price in the Deluxe Camcorder System (see fig. 3), and the other is to use an RF modulator to transfer the image to a standard television monitor. Both processes are made possible by the Pixelvision's internal playback devices, which perform a number of duties, as well as the supplied RF modulator and video cable.

First the camera must be placed in playback mode in order to connect the head to the playback preamplifier, as opposed to the write amplifier (used for recording). The signal from the tape is amplified to the appropriate level for the VCR circuit chip, which converts the signal to video. Next, the signal runs through the clamping circuitry, which is used to control any wavelengths that may exceed set limits by raising or lowering the amplitude. The signal then runs through an A/D converter (analog to digital), in order for the information to run through the RAM (random access memory) at specified and timed intervals, controlled by the timing generator. Two frames are processed at a time by the RAM, converted back to analog, sent through the FM signal generator (RF modulator), and finally to the television monitor on either channel 3 or 4.

The most important part of the process to note is the timing of each frame, and the slow TV scanning rate. A television monitor could display four frames in the time it takes the Pixelvision image to transfer one frame from the VCR circuit to the RAM. This extra time for scanning allows the image to have a higher resolution, but it still sacrifices image

quality. Because of the slow scanning and lag time, the playback method only allows for 15 frames per second, causing the ‘ghost trail’ on television monitors that has become a part of the PXL-2000 aesthetic<sup>10</sup>.

Lastly, if an F-type adaptor were to be purchased separately, the Pixelvision could be connected to a standard VCR in order to perform live video recording onto VHS, or to record what has already been encoded on the audiocassette. This process was made simpler by modifications some users made to their devices, which will be discussed later.

### **Flops and Successes of the 1980’s**

In Andrea McCarty’s thesis, *Toying with Obsolescence*, she explores the factors that might have ultimately caused the PXL-2000 camera to fail in the marketplace<sup>11</sup>. It’s easy to blame the poor image quality, which hardly met the expectations of Betacam or Videomatic users at the time, but this explanation can’t entirely explain why the camera met such a quick demise. Other factors, such as cost, also played a role in the lack of sales. While the Pixelvision was much cheaper than its professional video counterpart, it might not have seemed to be a reasonable investment when it was marketed and manufactured as a child’s play thing. A parent might rather save the \$150 and wait for the price of other camcorders to decline, before letting their child direct the family home movies with an inferior recording device.

Another important factor to examine is the inherent risks that are taken when a company creates a proprietary format. As mentioned before, children making videos with

---

<sup>10</sup> Thomas Heidt, Camcorder, U.S. Patent 4,875,107, filed December 4, 1986, and issued October 17, 1989, 4-5.

<sup>11</sup> Andrea McCarty, “Toying with Obsolescence” (MS thesis, Massachusetts Institute of Technology, 2005), 49-51.

their PXL-2000 must rely on the camera apparatus to view what they have recorded.

Unlike a VHS tape, audiocassettes couldn't simply be traded and shared, as there was not a universal playback mechanism in every household that could read the video information encoded. It is clear that either not enough cameras sold to gain the significant momentum to create interest among a larger audience, and/or there was too much distaste for the aesthetic in order for Pixelvision audiocassettes to become a preferred video format.

A failed device from the same time period mentioned by McCarty is the Kodak Disc Camera, created by Kodak in 1982. The camera was loaded with cartridges containing fifteen exposures of tiny negatives that proved too grainy and ill defined when processed. Similar to the Pixelvision, this proprietary format was a sub-standard version of what was already available on the market, and it also required alternative processing than typical 35mm processing<sup>12</sup>.

A toy that can't go without mention is the Talkboy, created in 1992 by Tiger Electronics and selling for \$30. Compared to the Pixelvision, the Talkboy doesn't quite share a similar technological allure, as it is primarily a tool for recording your voice on an audiocassette without any accompanying visuals. What puts Talkboy on the list of successful electronic children's toys is its origination, and acclaimed creator, John Hughes. The Talkboy first appeared as a toy prop in the film *Home Alone 2: Lost in New York*, in which Macaulay Culkin's character uses it to record family members, manipulate his voice to book a hotel room, and to trick dim-witted adults<sup>13</sup>. The interest and demand

---

<sup>12</sup> "Bad Old Days: Kodak Disc 4000 Camera – Boing Boing Gadgets," Boing Boing Gadgets, <http://gadgets.boingboing.net/2008/03/31/bad-old-days-kodak-d.html>.

<sup>13</sup> "Talkboy in Fast Forward," *Philadelphia Daily News*, Dec 15, 1993, <https://ezproxy.library.nyu.edu/login?url=http://search.proquest.com/docview/429497511?accountid=12768>.



for the toy to be on the market persuaded Tiger Electronics to mass-produce the film prototype to make what would become one of the best selling Christmas gifts that year<sup>14</sup>.

The advertizing for the product essentially paid for itself, as *Home Alone 2* remained successful through the decade. The product also provided immediate satisfaction, allowing for the user to playback what had only been recorded seconds earlier without the hassle of cords, plugs, and monitors. Along with the variable tape speed that made everyone sound goofy, the product had a significant amount of positive qualities to attract children. The Talkboy later led to an entire line of audio related gadgets, including the Talkgirl, a pink version for the young girls who found the 'high-tech' grey too tacky.

In the case of video cameras that prevailed in the 1980's on until the 90's, it is hard to designate a single superior manufacturer or device, as this was a time for little standardization and many attempts to create the next reliable and affordable format or camera apparatus. In 1987 camcorders were a high commodity, as they were more compact and easily handled on the user's shoulder with the recorder integrated into the camera design (as opposed to being a portable deck connected via wire). Many companies created multiple variants, but all were looking for a light, high quality, and cheap recording process for the everyday user<sup>15</sup>.

One main format of choice was the VHS-C, used by JVC when creating the GR-C1 camcorder (1984), which became a popular option in the 1980's. This device was

---

<sup>14</sup> Babette Morgan, "The Talk of Toyland," *St. Louis Post*, Dec 19, 1993, <https://ezproxy.library.nyu.edu/login?url=http://search.proquest.com/docview/303690790?accountid=12768> (accessed November 27, 2011).

<sup>15</sup> "Evolution: Cameras become Camcorders." Total Rewind. <http://www.totalrewind.org/cameras.htm>.

particularly advanced since it allowed for instant playback. The Amstrad VMC100 followed as the cheap alternative, also recording onto VHS-C, but using a rather rudimentary recording system similar to the Pixelvision. However, the Amstrad was light, cheap, and easily handled in the palm of one hand. Overall, VHS-C, S-VHS, and Video8 (later developed as Hi8) created higher resolution and color images with more tape space for longer recording times, proving the audiocassette to be an inadequate format for its time.

### **Experimental Artists, Circuit Benders, and Eight Year-Olds**

The PXL-2000 may not have reached its intended audience, nor had a well-timed entrance into the fast-paced, burgeoning world of new gadgets, but it has won the admiration of a select few underground communities since the early 90's. These communities follow a DIY (do-it-yourself) kind of mentality, embracing the crude qualities of Pixelvision and using its aesthetic as a major theme in their artworks or modifications. To an eight-year old, the Pixelvision may be just another obsolete toy that is quickly tossed in the toy chest with the View-Master, but to video artists and circuit benders, it is a medium for which to question art and play, and to experiment with altered images and signals.

“The camera aimed directly at her own face, the background drops away into a pixel abyss... This creates a strong feeling of intimacy...offering the point of view similar to that of a lover's embrace... As a closeup of a single eye fills the screen, we watch her open herself in a blend of bravery, trust, nai'vete, and defiance. One never feels that this

eye staring back at us has anything to do with formal (self-reflective) notions of media art. It's just too frighteningly personal for that<sup>16</sup>.” – Chris Chang, *Up in Sadie's Room*

The visual artist most known for their use with the Pixelvision was Sadie Benning. Benning was fifteen when she was given a Pixelvision for Christmas. Expecting something a bit more advanced in technology, she was first put-off by the toy. Soon she started filming herself, creating her own video diaries in the privacy of her room. Her coming of age experiences and subsequent coming out as a lesbian in Milwaukee were captured on Fisher-Price static and pixels. The product itself, not quite for children, yet not meeting the caliber of mature professional technology, paralleled these adolescent moments in Benning's room, where her development was unfolding before the camera lens.

Benning's work continued with the Pixelvision, and many of her pieces have subsequently been transferred to other formats in order to be exhibited at festivals and in installation works.

Along with video artists, there is yet another marginal group still playing with the PXL-2000. These people are called circuit benders, and they primarily reveal their presence via online community message boards and personal websites<sup>17</sup>. Many of these individuals have strong interests in the obsolete, but also finding ways in which to 'bend' the circuitry of discarded technologies, to craft new sounds and images.

---

<sup>16</sup> Chris Chang, "Up in Sadie's Room," *Film Comment*, <https://ezproxy.library.nyu.edu/login?url=http://search.proquest.com/docview/1706448?accountid=12768>.

<sup>17</sup> See <http://billtmiller.com/circuitbending/waterhed/>

Some modify the Pixelvision with intent to sell a new and improved product (sometimes for around \$500), while others enjoy bending as a hobby, wishing to stretch the limits of an already weak device or grainy image. One of the main modifications performed is the inclusion of audio and video outputs that can accept RCA or composite video cables, allowing for the image to be transferred live, or by playback, into an alternative recording device (such as a miniDV camcorder). This modification supplies the Pixelvision user with more avenues for reaching an audience, leaving the outmoded audiocassette behind.

There are also modifications that provide the user with more control over the image, such as a light level adjustment knob, fades, and freeze frame capabilities. Other circuit benders go a step further, creating switches and buttons to manipulate the image, blurring pixels, or creating strobe effects<sup>18</sup>.

Pixelvision camcorders also tend to run into problems with motor belts decaying, dirty heads, debris near the CCD, and battery corrosion. Some circuit benders provide simple repair for a price, which could significantly extend the life of the camera.

### **Battery Rust, Motor Belts, and Sticky Shed Syndrome**

There are multiple inherent issues within the camera technology and the audiocassette, making preservation a pressing issue for video that remains on audiotapes. With the Pixelvision acting as its own playback device, it is important to keep it in working condition, so as to use it (preferably one that is modified) to transfer the information from cassette to another format.

---

<sup>18</sup> See <http://bentstruments.com/pxl/pxl.html>

Problems found within the Pixelvision (broken drive belts, fogged lens, debris, battery corrosion, etc) inhibit the camera from reading the cassette, rendering it useless as a playback mechanism. It is not known how many cameras are still in working condition, but there is evidence to suggest (by the multiple services providing repair) that many need restoring, especially now that over 20 years have passed since their manufacturing.

Long understood preservation issues with audiocassettes include: shrinkage, brittleness, and sticky shed syndrome. Sticky shed syndrome occurs when the tape binder has become weak, causing particles to flake off. These particles create problems within the playback device and the tape signal. In most of these situations it is likely that the cassette has been stored in a high temperature and high humidity environment<sup>19</sup>. Tapes also become weakened when left in the Pixelvision tape path for long periods.

As mentioned before, migration is an important action to take place in order to preserve video encoded on an audiocassette. With the Pixelvision having been a rather cheap piece of machinery, it experiences detrimental wear and tear affecting its functioning capabilities. The audiocassette is also not the safest carrier for data, much less visual data, which can only be retrieved with the Pixelvision as its playback mechanism.

## **Conclusion**

Despite PXL-2000's seemingly innovative technology, using an audiocassette for video recording purposes was just not an ideal concept in a time of alternative and more promising formats. It also did not appear in a high grossing holiday movie hit like the

---

<sup>19</sup> Majella Breen, et al. "Technical Selection Criteria," *Task Force to establish Selection Criteria*, IASA, <http://www.iasa-web.org/task-force/3-technical-selection-criteria>.

Talkboy, nor did it have the luxury of color pixels or high resolution. Yet the camera did experience a sort of underdog victory through the decades following the discontinuation of its manufacturing.

Many obsolete formats and technologies are respected in a passive and nostalgic way, but few continue to have invested users exploring and manipulating its processes in an attempt to find its limits, surprises, and metaphorical leanings. The Pixelvision might never have become a treasured childhood toy, but it became a means of expression for at least one visual artist, while acting as a malleable tool to others who sought to exploit its flaws in search of a new aesthetic.

The circuit benders are in fact conservationists, repairing the few remaining models, and employing new methods for recording and migrating works through their modifications. Sadie Benning may not be creating Pixelvision shorts in her room anymore, but if she were, her grainy confessions would be accessible, as the PXL-2000 community has created quite a self-sufficient system, even without the help of the original proprietor, Fisher-Price.

## Bibliography

- "A Camcorder the Kids Can Call Their Own." *Consumer Reports* V. 53 (July 1988) P. 423. 53: 423.
- "Bad Old Days: Kodak Disc 4000 Camera – Boing Boing Gadgets." Boing Boing Gadgets. <http://gadgets.boingboing.net/2008/03/31/bad-old-days-kodak-d.html>.
- Breen, Majella, et al. " Selection Criteria." *Task Force to establish Selection Criteria*. IASA. <http://www.iasa-web.org/task>.
- Chang, Chris. "Up in Sadie's Room." *Film Comment*., <https://ezproxy.library.nyu.edu/login?url=http://search.proquest.com/docview/1706448?accountid=12768>.
- Enticknap, Leo. *Moving Image Technology: from zoetrope to digital*. London: Wallflower, 2005.
- "The Exciting and Ever Fascinating Pxl 2000." Benstruments.com. <http://benstruments.com/pxl/pxl.html>.
- Hain, Andy "Evolution: Cameras become Camcorders." Total Rewind. <http://www.totalrewind.org/cameras.htm>.
- Heidt, Thomas. Camcorder. U.S. Patent 4,875,107, filed December 4, 1986, and issued October 17, 1989.
- McCarty, Andrea, "Toying with Obsolescence" (MS thesis, Massachusetts Institute of Technology, 2005).
- Miller, Bill. "Waterhed – Circuit Bender." <http://billtmiller.com/circuitbending/waterhed/>.
- Morgan, Babette. "The Talk of Toyland." *St.Louis Post*, Dec 19, 1993. <https://ezproxy.library.nyu.edu/login?url=http://search.proquest.com/docview/303690790?accountid=12768>.
- PXL 2000 User Manual* (New York: East Aurora, 1987).
- "Talkboy in Fast Forward." *Philadelphia Daily News*, Dec 15, 1993. <https://ezproxy.library.nyu.edu/login?url=http://search.proquest.com/docview/429497511?accountid=12768>.

## Appendix A

Figure 1

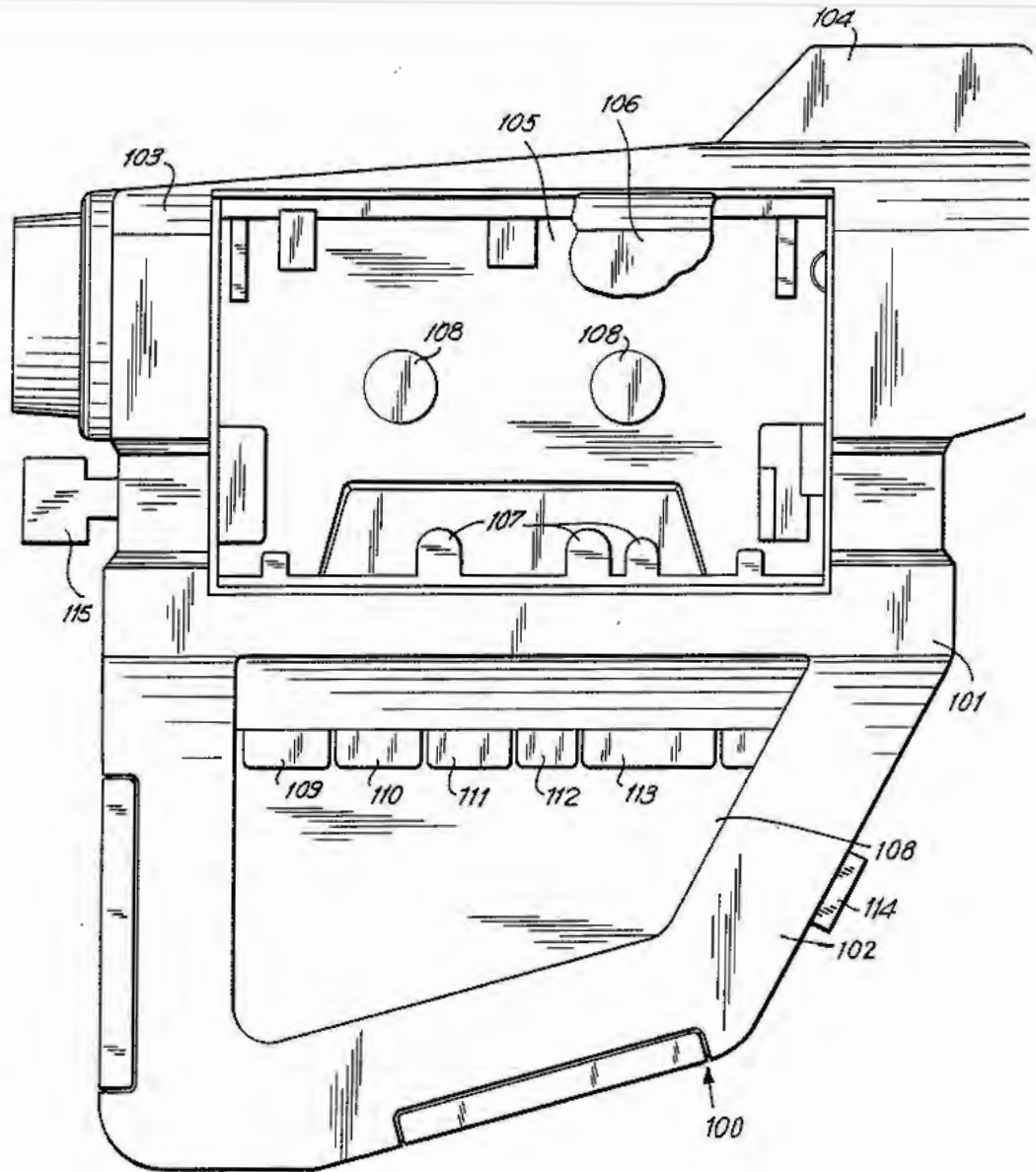

Heidt, Thomas. Camcorder. U.S. Patent 4,875,107, filed December 4, 1986, and issued October 17, 1989. Fig. 1.



Figure 2

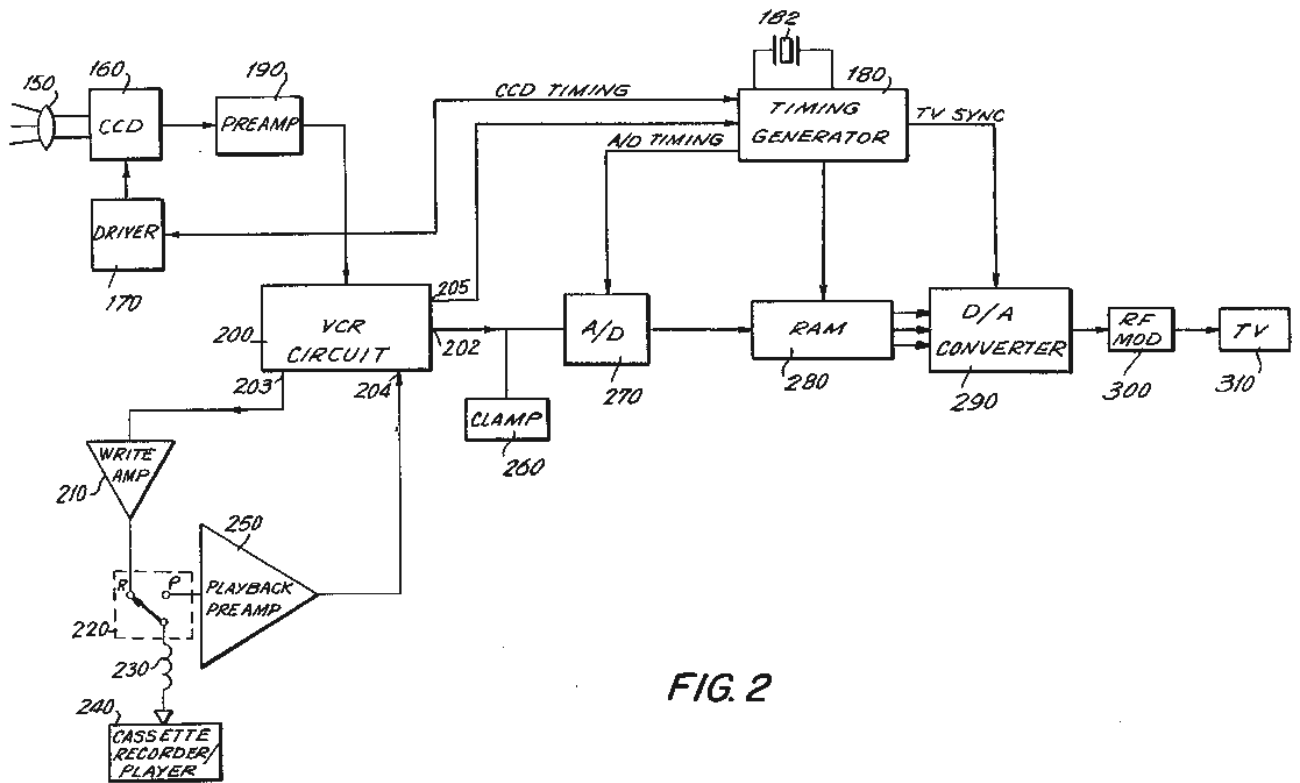

FIG. 2

Heidt, Thomas. Camcorder. U.S. Patent 4,875,107, filed December 4, 1986, and issued October 17, 1989. Fig. 2.

## Annotated Bibliography

**Books**

**Enticknap, Leo. *Moving Image Technology: from zoetrope to digital*. London: Wallflower, 2005.** This book explores the history of film projection and the standardization of film and digital mediums. While it does not contain any direct information regarding the Pixelvision, it is a reliable source on the general properties and histories of magnetic tape and CCD's that is not available in other questionable online sources.

**Articles**

**"A Camcorder the Kids Can Call Their Own." *Consumer Reports* V. 53 (July 1988) P. 423. 53: 423.** This report gives a very general description of the Pixelvision functions and how it might not necessarily be appreciated by children of the color TV generation. It was not a major source for this paper, but provided a general idea of how the product was perceived in 1988.

**Chang, Chris. "Up in Sadie's Room." *Film Comment*.**  
<https://ezproxy.library.nyu.edu/login?url=http://search.proquest.com/docview/1706448?accountid=12768>. This article explores the work of Sadie Benning in relationship to the Pixelvision and her experiences growing up. Chang speaks more to the metaphorical meanings behind the Pixelvision aesthetic, and how it was coupled with Benning's work and themes. The article was helpful in providing an alternative, non-technical view of the Pixelvision's history and style.

**Morgan, Babette. "The Talk of Toyland." *St. Louis Post*, Dec 19, 1993.**  
<https://ezproxy.library.nyu.edu/login?url=http://search.proquest.com/docview/303690790?accountid=12768>. It was important to stress the success of the Talkboy in comparison to the Pixelvision, which this article explored. It follows the Talkboy in relation to *Home Alone 2*, and the demand following its release into Toy stores before Christmas.

**"Talkboy in Fast Forward." *Philadelphia Daily News*, Dec 15, 1993.**  
<https://ezproxy.library.nyu.edu/login?url=http://search.proquest.com/docview/429497511?accountid=12768>. This article follows the Talkboy craze, explaining its popularity, and the role of John Hughes and Tiger Electronics in the creation of the product.

**Websites**

**"Bad Old Days: Kodak Disc 4000 Camera – Boing Boing Gadgets." Boing Boing Gadgets. <http://gadgets.boingboing.net/2008/03/31/bad-old-days-kodak->**

**d.html.** This site quickly explores the downfalls of the Kodak Disc 4000 camera, explaining its functions and time period.

**Breen, Majella, et al. "Selection Criteria." *Task Force to Establish Selection Criteria.***

**IASA. <http://www.iasa-web.org/task>.** This website contains valuable information in relation to the preservation of various media. The areas surrounding magnetic tape preservation issues were useful for this paper in understanding the general deterioration process involved with sticky shed syndrome. The IASA is also a very dependable association as it stays abreast with new ideas and techniques within the field.

**"The Exciting and Ever Fascinating Pxl 2000." *Benstruments.com.***

**<http://bentstruments.com/pxl/pxl.html>.** This website was created by one of the more prolific circuit benders, who provides a list of modifications he has made to the Pixelvision. There are also videos and screenshots as visual examples of ways in which the signal and aesthetic can be modulated. Of all the circuit bender websites, this one provides the most exhaustive list of successful modifications.

**Hain, Andy. "Evolution: Cameras become Camcorders." *Total Rewind.***

**<http://www.totalrewind.org/cameras.htm>.** This site examines the evolution of cameras to camcorders, providing images, descriptions, and technical information for various camera systems in the 1980's. The site also includes the Pixelvision, and contains relevant information relating to its general design, marketing history, and underground following. This source proved to be extremely helpful in placing the Pixelvision within the context of alternative formats and recording devices during its time.

**Hess, Richard. "Richard L. Hess's Tape Restoration Resources." *Richard L. Hess Mary Beth Hess Home Page.***

**<http://www.richardhess.com/tape/index.htm>.** Although not used for this paper, this site contains a wide range of tape formats, and basic information with figures to help explain functions.

**Miller, Bill. "Waterhed – Circuit Bender."**

**<http://billtmiller.com/circuitbending/waterhed/>.** This circuit bending site not only explores an individual's work with the Pixelvision, but other children's gadgets as well. It provides similar information to other circuit bending sites, but also contains an image of the modified camera, with labels for the new buttons and knobs that were incorporated. More importantly, this site provides a look into the inner workings and personality of the circuit bending community.

## Other

**Bogart, John. *Magnetic Tape Storage and Handling. A Guide for Libraries and Archives. The Commission on Preservation and Access. 1995.***

**<http://www.clir.org/PUBS/reports/pub54/index.html>.** This is an extensive and reliable report on techniques and practices for preserving and conserving magnetic media.

**Heidt, Thomas. Camcorder. U.S. Patent 4,875,107, filed December 4, 1986, and issued October 17, 1989.** The patent, although dense and formal, details most functions of the Pixelvision. There was nothing in the way of how the audio recording process was imagined, but the figures and technological information provided a great starting point for research. The patent also worked as a solid outline and foundation for the camera functions, although it was clearly not meant as an explication for the less technologically minded.

**McCarty, Andrea, “Toying with Obsolescence” (MS thesis, Massachusetts Institute of Technology, 2005).** This dissertation was one of the primary sources that led most of the research and organization of this paper, as it covered many aspects of the Pixelvision history. There are very few technical details, but the paper works as a starting point for angles to focus more directly on (such as user-groups and marketability).

***PXL 2000 User Manual* (New York: East Aurora, 1987).** The user manual for the Pixelvision pairs well with the patent as it contains clear pictures, figures, and operating procedures meant for the every day consumer. The manual also provides information regarding the functions in layman’s terms, which helped clear up the cluttered wording found in the patent. This document was also an important artifact in itself, as it accompanied the camera when it was originally purchased.