

Candace Ming

Prof. Harris

Moving Image and Sound

11/19/09

2" Helical IVC-9000

In 1973 the International Video Corporation (IVC) debuted their new video tape recorder for broadcast: the VR-9000. The VR-9000 was considered revolutionary. It answered the demands in the industry for compatibility for the PAL (European) standard for broadcast and introduced the segmented scan recording technique to the television community.

Using a 2" ferrite oxide based tape; the VR-9000 contained a cue, control, time code, and two audio tracks (Appendix I).

In order to understand how the VR-9000 works it is important to understand television broadcasting. In the early days of television programs were filmed and then transferred to tape using a process called kinescope. This process was both expensive and impractical. The television industry began seeking a way to time-shift programs so that they would be available to the west coast. The cost and time of developing kinescope prints often created a delay in broadcast for regions not in the production area. In 1956 Ampex developed the VR-1000. Using magnetic recording technology, previously used in audio recording, the VR-1000 was able to record video with less cost and more portability. Stations could now send tapes directly to other markets without the lengthy developing times necessary when using the kinescope method.

Ampex, and other companies, initially developed machines featuring 2” tape using an arcuate scanning method. The tape was laid flat against a spinning disk with heads on its face. The path of the tape makes an arc, thus the name. This method was eventually abandoned due to short recording time, instability, low picture quality, and because of significant reproduction issues. An artifact known as “banding” or “ventian blinds” was present in arcuate designs¹. The defect is caused by synchronization errors during playback when merging the two head signals. The effect is generally caused by differences in head efficiencies and differing head-tape spacing.² Both of these problems are inherent in the design of the arcuate recorder because of the way the tape passes through the record heads. Due to its orthogonal nature and its arc path along the tape there is little stability resulting in various errors in playback.³ It is worth mentioning this format as an predecessor to the quadruplex recorder, which fixed many of the issues of the arcuate scanning method.

The Ampex quadruplex recorder (VR-1000) uses a transverse scanning method where the tape is perpendicular to the rotating heads. It’s name comes from the four rotating heads that the tape must pass through in order to register a full frame or picture. The first quadruplex used 2” tape, which allowed for the largest amount of picture area, plus additions for audio and control tracks. Originally only available for monochrome broadcast the quadruplex was eventually adapted for color broadcast in 1964. The VR-

¹ Daniel, E. D., Mee, C. D., Clark, M. H., Ed., Nielsen, H., Engel, F. K., et al. (1999).

Magnetic recording: The first 100 years., 341.

² *ibid*

³ *ibid*

1000 features a rotating drum, of 2-inch diameter, with four heads arranged around it, also known as quadrature scan.⁴ The drum is actually aligned perpendicular with the head so that the video information is arranged in vertical lines along the tape. The VR-1000 also featured an audio, control, and cue track along the edges of the tape (Appendix I). The first tape used was a polyethylene terephthalate, or Mylar, base of 1mm and a ferrite oxide coating of 5mm.⁵ This construction was chosen for durability and stability and could go through around 100 passes.⁶

The improved picture quality and efficiency of the quadruplex recorder made it a standard for the broadcast industry for around 25 years.⁷ Through continued development it was able to handle all facets of the industry from production to post-production. However, the major drawbacks of quadruplex recorders were both the expense and, at least in the beginning, the difficulty of editing. For local stations the expense of the equipment and tape stock for a quadruplex recorder was prohibitive. The picture quality was also not the best. The transverse scan method recorded about 400 horizontal lines of resolution. The standard for NTSC is 525 and for PAL 625. Obviously there is a large

⁴ *ibid*

⁵ Downing, M. S. E. (1970). The world of helical scan. *British Kinematography, Sound & Television*, 52(11), 344-354.

⁶ Daniel, E. D., Mee, C. D., Clark, M. H., Ed., Nielsen, H., Engel, F. K., et al. (1999). *Magnetic recording: The first 100 years.*, 341.

⁷ *ibid*

difference in quality because the more lines the greater resolution of the image. The scanning method was also slightly unstable. Precise timing was needed to reconstruct the image otherwise the banding effect could occur. There was no time-base corrector available for the quadruplex recorders and their demise was inevitable in the face of a new, cheap, and more efficient type of recorder: helical scan.

Ampex was again at the forefront of this development. Using the helical-scan method they created several video recorders in the early sixties. The VR-660 was more portable and less expensive than quad recorders on the market. It could record up to 4 hours of tape, but was still extremely bulky, as it required a larger drum for its two scanning heads. The tape layout was nearly the same as the quad layout without a cue track. Instead it featured two audio tracks and a control track (Appendix II).

The helical scan method allowed for more room on the tape for field registration resulting in increased tape recording length. Sony also developed a 2-inch recorder using a 1.5-head helical scan. This scanning method featured a kind of control head that recorded the vertical synchronization. The main head recorded the video signal.

In order to understand helical scan we must first examine its design. First developed by Alex Masey at Ampex it didn't fully take off as a scanning method until the 1970's when improved head and tape technology rendered it more efficient and cost-effective than the then dominant quadruplex recorders. There are two main configurations of helical scan. The omega and alpha wrap. The alpha wrap requires only one head and

the tape is wrapped a full 360 degrees around a male guide.⁸ The omega wrap requires two heads and wraps 180 degrees around a male guide.⁹ The difference between the two wraps is essentially a loss of information. In an alpha wrap there is a point where the head leaves the tape to begin scanning a new line. While the gap is measured in microseconds it is still a loss of picture information. The omega wrap, in contrast, contains no point where the head and tape are not in contact. Which wrap is used depends on the recorder in question. The helical scan method also records a complete field with each pass of the head. As mentioned before, quadruplex recorders only record portions of the field making switching difficult. Also impossible is the ability to freeze the image or fast forward through. Helical scan solved this problem. The heads record a complete field of the frame making it possible to stop the image as well as shuttle back and forth between images.¹⁰

After all of these developments in helical scan recorders a significant problem had never been addressed. The problems inherent in switching between the NTSC and PAL standards. In North American we use the NTSC standard where the frame contains 525 lines at 30 frames per second. In Europe they use PAL, which is 625 lines at 25 frames

⁸ Downing, M. S. E. (1970). The world of helical scan. *British Kinematography, Sound & Television*, 52(11), 344-354.

⁹ *ibid*

¹⁰ Downing, M. S. E. (1970). The world of helical scan. *British Kinematography, Sound & Television*, 52(11), 344-354.

per second. In North American we use a frequency of 60Hz while in Europe they use 50Hz.¹¹ These differences presented major problems in recording and playback across standards. The frequency generally refers to the number of fields scanned per second, a field being made up of one half of the television picture (horizontal or vertical). Helical scan did not at first make up for the differences in standards, but it did simplify the quadruplex scan method. Instead of each head recording only part of a field, one head could now record a complete field. Another development in helical scan was called segmented scan. This method allowed for the different frequencies in the NTSC and PAL broadcast standards. By dividing the frame into segments rather than recording a whole field the head would record a portion of a field. These corresponded to the synchronized frame frequency for the NTSC and PAL standards, 60Hz and 50Hz.¹² Since these segments corresponded to 52 lines for each standard it was now possible to record in both standards on one machine without changing out drums. Previous methods required the changing of drum heads to maintain the same head to tape speed.

However, up until the early seventies helical scan was not in definite competition with quadruplex recording. The technology had not advanced far enough to allow for

¹¹ *Magnetic recording*(1987). In Daniel E. D., Mee C. D. (Eds.), . New York: New York : McGraw-Hill.

¹² Daniel, E. D., Mee, C. D., Clark, M. H., Ed., Nielsen, H., Engel, F. K., et al. (1999). *Magnetic recording: The first 100 years.*, 341.

time base correction in broadcast. There was not enough of a delay to compensate for any errors in playback.¹³ Helical scan recorders were mostly used in institutional situations where playback did not need to be as precise as in a broadcast setting. The large head drum required to maintain the same head to tape speed as the quadruplex recorder (which resulted in better picture quality) necessitated a complicated tape path.¹⁴ This path produced significant time based instability rendering it unsuitable for broadcast.¹⁵

The International Video Corporation introduced their Model 9000 in 1973. The goal of the machine was to provide a high quality recorder capable of broadcast standards and without the time-based instability in earlier helical scan recorders. The 9000 employed a segmented helical scan method, which allowed it to conform to PAL and NTSC standards without changing the tape or head-drum rotation speed.¹⁶ The 9000 cut the tape length in half using the segmented scan method and eliminated the need for both

¹³ Hartwig, R. L. (1990). *Basic TV technology*. Boston: Boston : Focal Press.

¹⁴ *Magnetic recording*(1987). In Daniel E. D., Mee C. D. (Eds.), . New York: New York : McGraw-Hill.

¹⁵ *ibid*

¹⁶ Daniel, E. D., Mee, C. D., Clark, M. H., Ed., Nielsen, H., Engel, F. K., et al. (1999). *Magnetic recording: The first 100 years.*, 341.

a cue and address audio track (Appendix III).¹⁷ The 9000 also included a time-base corrector and dropout compensation. The 9000 was revolutionary in providing a high quality signal, but using half the tape of the comparable quadruplex recorder. It used the super high band frequency of 9.9-12.3MHz. It also included two high quality audio tracks as well as cue, control, and a SMPTE address track. The operating costs were low because of the need for less tape and it was initially priced at \$100,000.

Technically the 9000 was quite sophisticated. I have already mentioned the track layout, but each machine also included a time-base corrector, video monitor, waveform monitor, and vector scope (Appendix IV). IVC also developed several different variations of the 9000 machine. The 9000-4, 9000-W, and 9000-M all offered different features than the original 9000. The 9000-4 had a longer record and playback time, up to 4 hours, using a long play format. It essentially halved the tape speed of the 9000 (8ips to 4ips) allowing for increased recording time.¹⁸ The 9000-W had a super high bandwidth of 8Mhz! Previous bandwidths were constrained by technology to around 4Mhz leading to low picture quality. Super high band was developed in 1971. It reduced high frequency jitter

¹⁷ Daniel, E. D., Mee, C. D., Clark, M. H., Ed., Nielsen, H., Engel, F. K., et al. (1999).

Magnetic recording: The first 100 years., 341.

¹⁸ “IVC videotape format - Wikipedia, the free encyclopedia.” Web. 15 Oct 2009.

and allowed recording at greater bandwidths resulting in nearly perfect picture quality.¹⁹ The 9000-M had increased resolution scanning 655 lines at 24fps. The 9000W-M was a combination of the two formats allowing for super high band recording and a higher resolution.

However, though the 9000 was considered revolutionary it quickly failed as a broadcast system. The 9000 used 2” tape, which was costly and at the same time to VTR’s using 1” tape were brought to the market. These new VTR’s had nearly the same picture quality as the 9000 and were much less expensive. The new systems were also much smaller and far more portable than the 9000, which because of the tape width necessitated large drum size and frame.²⁰ Though the 9000 was capable of super-high-band Ampex had initially developed the technology. Broadcasters who already used quadruplex recorders could add this to technology to their existing equipment relatively inexpensively.²¹ There was no incentive to purchase the 9000 when both old and new

¹⁹ *Magnetic recording*(1987). In Daniel E. D., Mee C. D. (Eds.), . New York: New York : McGraw-Hill.

²⁰ Downing, M. S. E. (1970). The world of helical scan. *British Kinematography, Sound & Television*, 52(11), 344-354.

²¹ Abramson, A. (2003). *The history of television, 1942 to 2000*. Jefferson, N.C.: Jefferson, N.C. : McFarland & Co.

technology was either matching or surpassing its features. In all IVC sold only 300 units and declared bankruptcy in 1977.²²

As mentioned previously, old and new technology was quickly meeting the demands for higher bandwidth and better resolution. Quadruplex recorders were being augmented to allow for higher bandwidth and new recorders were entering the market. The SMPTE Type B and Type C standards both used only 1-inch tape. A considerably less expensive format. The size also contributed to decreasing the weight and bulkiness of recorder devices. These standards were also able to broadcast at nearly the same picture quality and resolution as the 9000 and quadruplex recorders, but at less cost!

The Type B standard was produced by Bosch in Germany. It used a segmented scan method with a 1-inch tape. The track included three audio tracks, two high fidelity and one timecode track. It was compatible with both the NTSC and PAL standards and recorded at 5.5Mhz. It recorded up to 90 minutes of video. Though not successful in North American markets it did compete successfully with the quad recorders in Europe.²³

The Type C standard quickly replaced quadruplex recorders in North America. Developed by Ampex and Sony the format had many of the same features as the Type B. However it was capable of trick play functions because it did not use the segmented scan method. It also used 1-inch tape resulting in a smaller and less costly device.

²² *ibid*

²³ Daniel, E. D., Mee, C. D., Clark, M. H., Ed., Nielsen, H., Engel, F. K., et al. (1999).

Magnetic recording: The first 100 years., 341.

In closing the 9000 was only around for a few years, but it made radical strides in the field of helical scan recording. It's use of the segmented scan method decreased costs and offered interoperability between the NTSC and PAL standards. It also made use of higher resolution and higher bandwidth technology resulting in greater picture quality. The 9000W-M is almost a precursor to HDTV in terms of its high resolution.²⁴ The downfall of the 9000 was its use of 2-inch tape. If IVC had decreased their tape width it might have become a staple of the broadcast industry dethroning the quadruplex recorder as the medium of choice. However, the introduction of formats using smaller tape width and the capability of improving on old devices effectively rendered the 9000 useless. Its features were copied in both old and new formats and it simply could not compete in an industry where portability and cost-effectiveness drive the market.

²⁴ "IVC videotape format - Wikipedia, the free encyclopedia." Web. 15 Oct 2009.

Appendix I

Detail of the tape path for a transverse scan recorder.²⁵

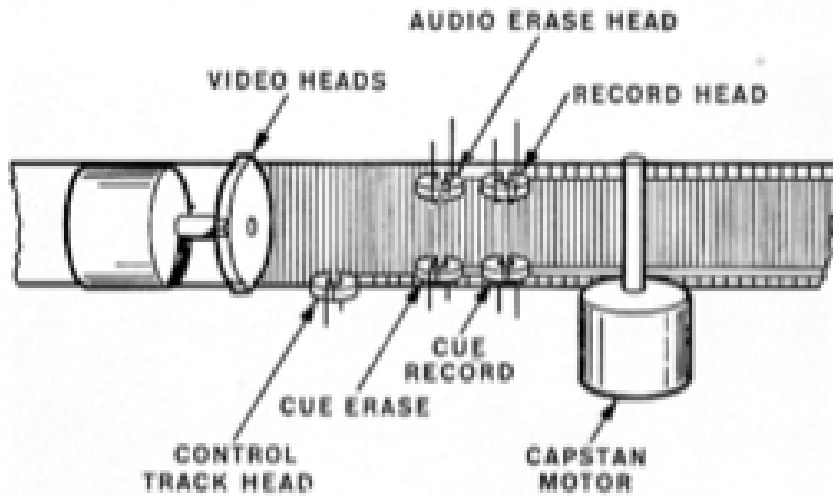

Fig. 3. Transverse scan recorder.

²⁵ Downing, M. S. E. (1970). The world of helical scan. *British Kinematography, Sound & Television*, 52(11), 344-354.

Appendix II

Detail of the Ampex VR-1500 track pattern, one of two Ampex products that used 2" tape. The other was the VR-660, which used the same track pattern.²⁶

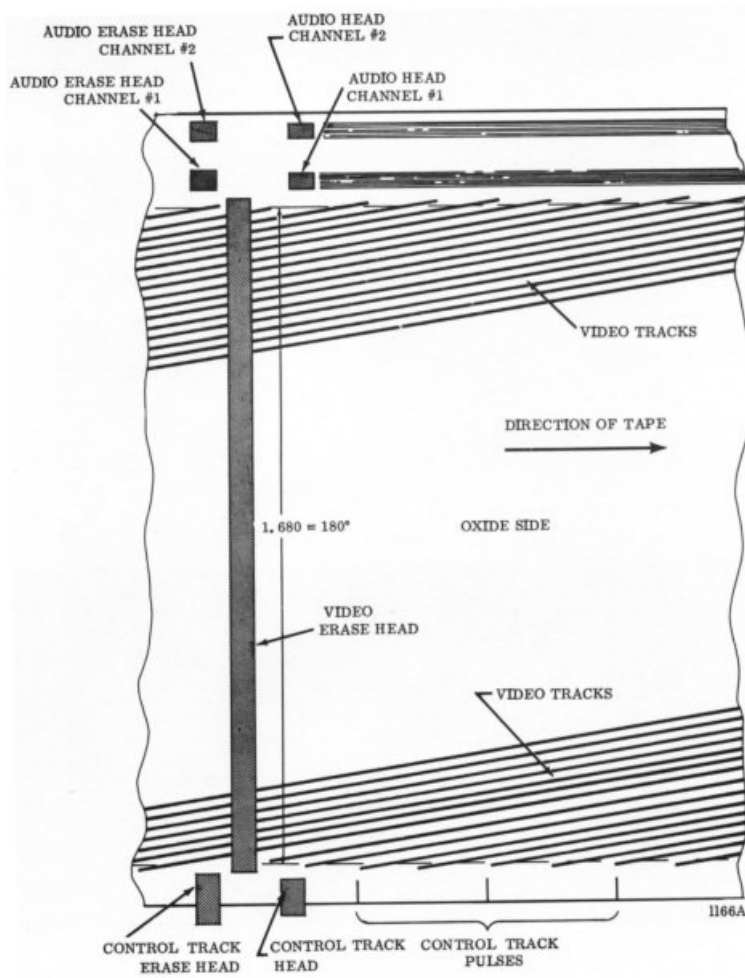
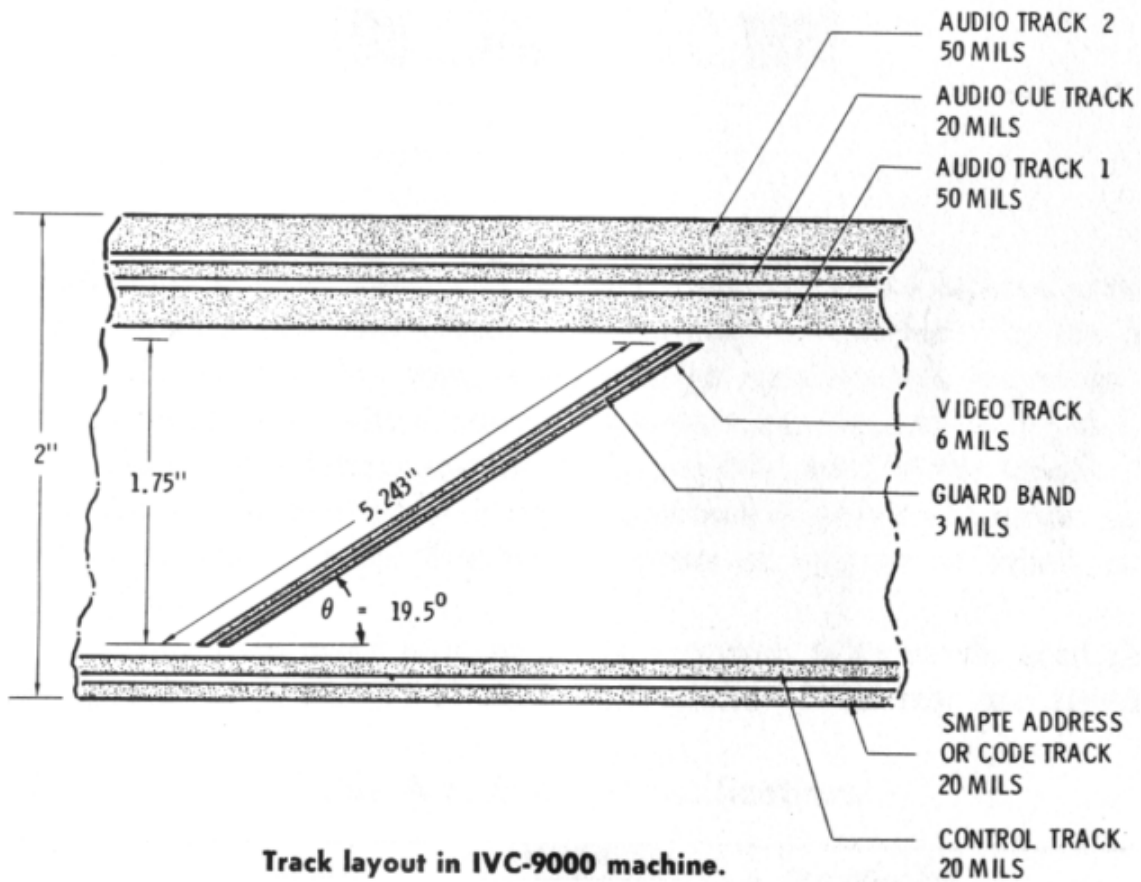

Figure 1.1-3. Track Patterns, VR-1500

²⁶ Downing, M. S. E. (1970). The world of helical scan. *British Kinematography, Sound & Television*, 52(11), 344-354.

Appendix III

Detail of the IVC Model 9000 Track Layout. Included a SMPTE address track as well as two high quality audio tracks. Plus the standard cue and control tracks.²⁷



²⁷ "LabGuy's World: IVC-9000 Format." Web. 18 Nov 2009.

Appendix IV

Photo of the IVC-9000. Shown on the upper right are the waveform and vectorscope monitors.²⁸



²⁸ “LabGuy's World: IVC-9000 Format.” Web. 18 Nov 2009.

Bibliography

Abramson, A. (2003). *The history of television, 1942 to 2000*. Jefferson, N.C.: Jefferson, N.C. : McFarland & Co.

A complete history of the development of television. The book offers a month by month outline of developments and changes in the industry. It also features some technical data on various formats.

Daniel, E. D., Mee, C. D., Clark, M. H., Ed., Nielsen, H., Engel, F. K., et al. (1999). *Magnetic recording: The first 100 years.*, 341.

This is a series of articles about the developments in magnetic recording. The articles encompass audio, video, as well as digital formats. Many of the articles are written on particular formats of magnetic recording and provide great technical detail.

Downing, M. S. E. (1970). The world of helical scan. *British Kinematography, Sound & Television*, 52(11), 344-354.

A brief overview of the principles of helical scan recording. It is highly detailed and examines the benefits and problems associated with the method. It also briefly details the structure of quadruplex recording.

Hartwig, R. L. (1990). *Basic TV technology*. Boston: Boston : Focal Press.

A handy guide to understanding how television works. It provides a glossary of terms and is written in such a way that a layman can understand. There is brief discussion of formats, but it is not technically detailed.

Magnetic recording(1987). In Daniel E. D., Mee C. D. (Eds.), . New York: New York : McGraw-Hill.

A concise and detailed history of magnetic recording in video, audio, and digital realms. There is detailed histories and technical specifications of video recording methods.

Morrison, F. (1966). Helical scan video recording. *British Kinematography, Sound & Television*, 48(4), 108-115.

A very technical article describing the principles of helical scan. It describes frequency rates, principles, as well as design and layout of helical scan recorders

Nixon, N. (2004). 1964 - 1974. *IBE: International Broadcast Engineer*, 40, 26-27.

A short timeline of broadcast developments from 1964-1974. It briefly mentions the development of the IVC-9000.

“IVC videotape format - Wikipedia, the free encyclopedia.” Web. 15 Oct 2009.

A brief overview of the technical specifications for the IVC-9000. Useful in describing other iterations of the design and for a broad understanding of how the machine worked.

“LabGuy's World: IVC-9000 Broadcast Video Recorder: four technical papers.” Web. 18 Nov 2009.

A useful site devoted to extinct equipment. Photos, information, and technical specifications were available on the IVC-9000. Also a complete manual was found on the site relating to the development and precise workings of the recorder.

“LabGuy's World: IVC-9000 Format.” Web. 18 Nov 2009.

A picture of the track layout for the IVC-9000 recorder.

“VideOlson Videotape Formats.” Web. 19 Nov 2009.

A listing of the various tape formats including their year and tape width. Also listed was some information related to each format as well as the company that produced each recorder.